



Tel +1 (717) 767-6511
 Fax +1 (717) 764-0839
 www.redlion-controls.com

Bulletin No. S-SUB-D
 Drawing No. LP0084
 Released 4/02

SUPER SUB-CUB - 8-DIGIT COMPONENT COUNTER WITH 6-DIGIT LCD DISPLAY

U.S. PATENT NO. 4599600

IDEAL IN APPLICATIONS FOR:

- POSITION INDICATION
- COUNTING FROM MULTIPLE SOURCES
- FLOW MEASUREMENT
- MACHINE MONITORS
- SECURITY EQUIPMENT
- UTILITY METERS
- COMPUTERS
- VIDEO GAMES
- TEST EQUIPMENT
- MACHINE CONTROLS
- MEDICAL EQUIPMENT
- DISPENSING EQUIPMENT
- PORTABLE INSTRUMENTS



- TRUE QUADRATURE - WITH RESOLUTIONS UP TO 4 TIMES THE ENCODED INPUT
- BI-DIRECTIONAL COUNTING WITH UP/DOWN CONTROL
- ANTI-COINCIDENCE ADDITION AND SUBTRACTION
- POLARITY INDICATION
- 8-DIGIT COUNTING CAPABILITY (6-digit display)
- DECIMAL POINT AND LEADING ZERO BLANKING SELECTION
- SOLDERLESS, ELASTOMERIC INTERCONNECTS (Snap mounts directly on P.C. board)
- ULTRA LOW POWER, 25 µA AT 5 V (TYPICAL)

* ACCESSORY HARDWARE AVAILABLE FOR PANEL MOUNTING SUPER SUB-CUB

DESCRIPTION

As a completely self-contained counter/display module, the new SUPER SUB-CUB can be treated as a component just like any other I.C. The SUPER SUB-CUB provides all the capabilities and features of the SUB-CUB 2 plus four "built-in" modes of operation. These are: Bi-Directional counting with UP/DOWN control...ideal for length measurement, where change of direction can occur; Quadrature counting (two pulse trains, shifted from one another by 90°), commonly used for position applications; Anti-Coincidence Summing and Anti-Coincidence Add/Subtract counting...useful in applications where two

input signals from different sources occur at the same time. The SUPER SUB-CUB has the additional capability of inhibiting counts to both inputs, used under certain conditions to prevent false counts.

The SUPER SUB-CUB snap-mounts directly onto a 1/16" thick P.C. Board which has been etched with the proper mating pattern (shown below). Four elastomeric connectors provide corrosion-proof, gas tight contacts which afford high reliability. In addition, the SUPER SUB-CUB is available with a bezel mounting kit, which will allow the unit to be mounted as a panel instrument.

MOUNTING & DIMENSIONS In Inches (mm)

Snap in mounting on the P.C. Board is facilitated by two, split, lock-ramp pins which engage mounting holes drilled in the P.C. Board. The silicone rubber elastomeric connectors compress to accommodate P.C. Board thickness variation of ±0.005" (0.13 mm).

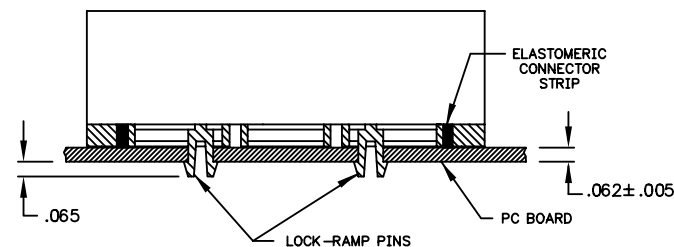

DIMENSIONS In Inches (mm)

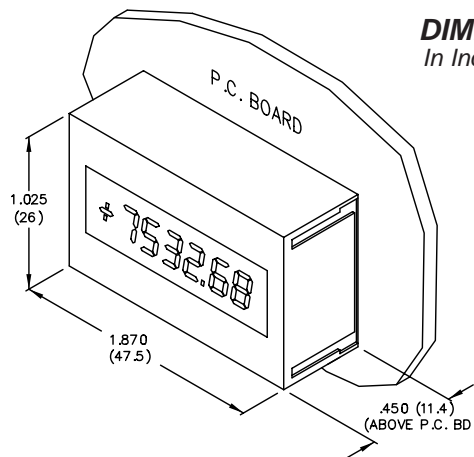

P.C. BOARD LAYOUT

P.C. Board pads may be gold or tin-lead plated. Pad surface must be flat without excessive tin-lead build-up. (Layout views are from SUPER SUB-CUB mounting side of board.)

Pad area must be clean and free of contaminants so that proper electrical contact can be made.

Note: All hole size tolerances ±0.003" (0.08 mm)
 All other tolerances ±0.005" (0.13 mm)

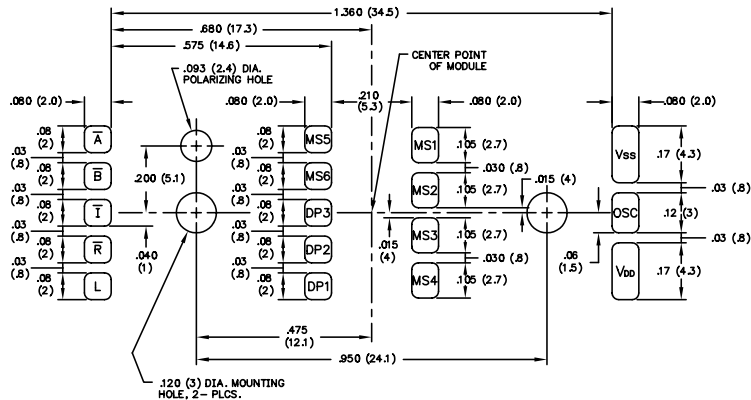

DEVICE CONNECTIONS *

COUNT (\bar{A}) - CMOS, Schmidt Trigger; used as count or count control input, depending on the mode of operation selected. It's generally used as a count input. See Modes of Operation for more details.

COUNT (\bar{B}) - CMOS, Schmidt Trigger; used as count or count control input, depending on the mode of operation selected. It's generally used as a count input. See Modes of Operation for more details.

RESET (\bar{R}) - CMOS Schmidt trigger; counter is reset and held to zero when this pin is at a low level.

INHIBIT (\bar{I}) - CMOS Schmidt trigger; all counting for all modes is inhibited when this input is at a low level. This input is asynchronous with inputs "A" and "B".

LATCH (L) - CMOS Schmidt trigger; data on the display is latched when this input is at a high level. This input has no effect on the counting operations of the unit and is asynchronous with inputs "A" and "B".

DP1, DP2, DP3 - CMOS level-sensitive; these inputs are used for decimal point selection and leading zero blanking selection. See Decimal Point and Leading Zero Blanking Selection for more details.

MS1, MS2, MS3, MS4, MS5, MS6 - CMOS level-sensitive; these inputs are used for Mode Selection. These modes include: Bi-Directional Counting, Quadrature Counting, Anti-Coincidence Summing and Anti-Coincidence Add/Subtract. See Modes of Operation for more details.

OSC. - This input provides for connection of an external 2.4 meg. resistor required by the on-board scan oscillator. The oscillator operates at 240 Hz \pm 35% and has an internal divider to provide 60 Hz back plane drive.

V_{DD} - 2.5 to 6 VDC Supply

V_{SS} - Common for D.C. Supply and Inputs.

* All other inputs must be tied to either V_{DD} or V_{SS}, whichever is appropriate.

BLOCK DIAGRAM

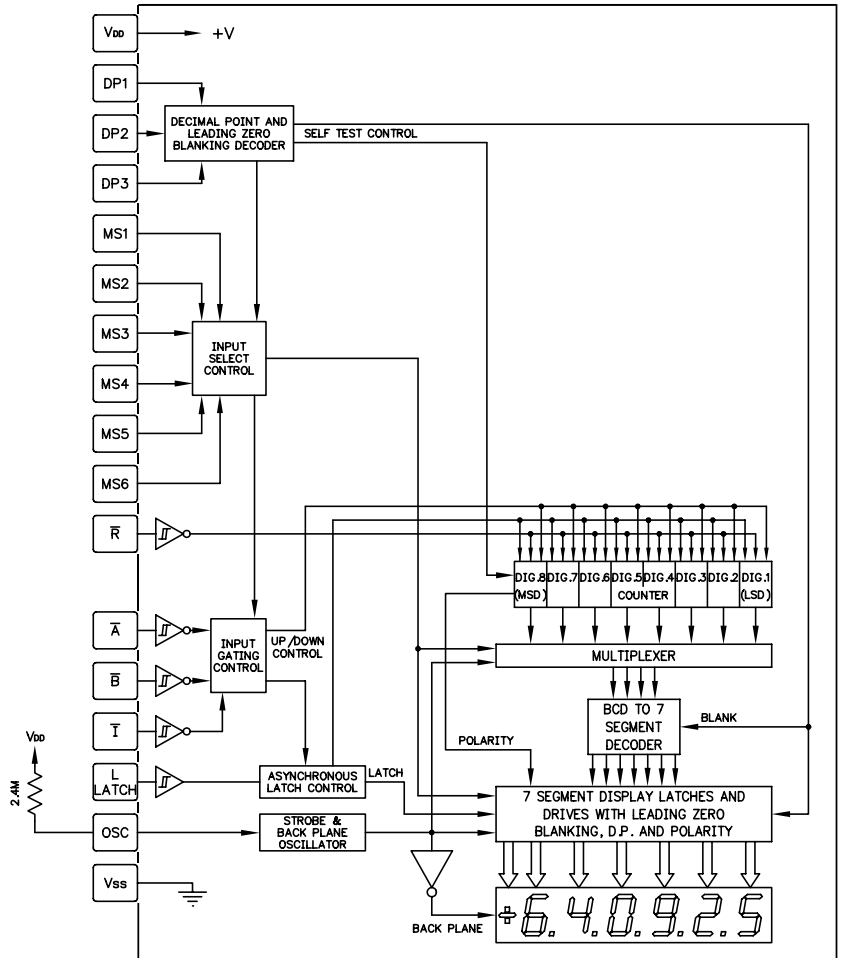

CAUTION

This device contains CMOS circuitry which requires special anti-static handling to the same degree required by standard CMOS integrated circuits. Units should be stored in the conductive packaging used to ship the devices. Containers should be opened and units handled only on a conductive table top by personnel wearing wrist strap grounding equipment. These devices have the same protection circuits as standard CMOS devices to prevent damage to inputs due to nominal over-voltage.

MAXIMUM RATINGS (VOLTAGE REF. TO V_{SS})

RATING	SYMBOL	VALUE	UNIT
DC Supply Voltage	V _{DD}	-0.5 to +6.5	VDC
Input Voltage, All Inputs	V _I	-0.5 to (V _{DD} +.5)	VDC
Operating Temperature	T _A	-35 to +85	°C
Storage Temperature	T _{STG}	-35 to +85	°C

ELECTRICAL CHARACTERISTICS V_{DD} = 5 V \pm 10% @ 20°C UNLESS OTHERWISE SPECIFIED

SYMBOL	PARAMETER	MIN.	TYP.	MAX.	UNIT	TEST CONDITION
V _{DD}	Supply Voltage	2.5 4.5		6.0 6.0	VDC	All Modes Except Anti-Coincidence Modes
I _{DD}	Supply Current Supply Current		25 60	40 100	μ A μ A	F _C = 10 KHz F _C = 10 K Anti-Coincidence Modes
I _{DDQ}	Quiescent Current		10	16	μ A	Not Counting
V _{IH}	Input High Voltage	3.9	3.0		VDC	
V _{IL}	Input Low Voltage		0.9	0.5	VDC	
I _{IL}	Input Leakage Current		0.01	0.1	μ A	V _{SS} < V _{IN} < V _{DD}
f _c max	Count Frequency (50% Duty Cycle)	400 250 200 100 20			KHz KHz KHz KHz KHz	X1, -10 & 100 Bidirectional Modes X2, -5 & 50 Bidirectional Modes X1, X2, -10, 100, 5 & 50 Quad. Mode X4, -2.5 & 25 Quadrature Mode Anti-Coincidence Modes
f _{osc}	Oscillator Frequency		240		Hz	R EXT = 2.4M
T _{RST}	Reset Pulse Width	10			μ S	

MODES OF OPERATION

BI-DIRECTIONAL COUNTING MODES

For Bi-Directional counting, input "A" serves as the count input, while input "B" serves as the direction control input. In the Times 1 Mode when "B" is at a low level, a negative going transition at "A" will cause the counter to count in the positive direction. When "B" is at a high level, a negative going transition at "A" will cause the counter to count in the negative direction. TABLE I illustrates the level settings of the Mode Select Inputs for the various modes of Bi-Directional counting. The Times 2 Mode works like Times 1 Mode except the counter changes on a positive going transition at "A", as well as on a negative going transition at "A". There are also two Divide-By Modes which prescale the display by 10 or by 100. This results in the capability of displaying the 7th and 8th digit of the internal counter. (Along with Times 2, this gives an equivalent -5 and -50 display.)

TABLE I

MODE	MS6	MS5	MS4	MS3	MS2	MS1
Times 1	1	1	0	0	0	0
Times 2	1	1	0	1	1	0
(x2, -10) Divide By 5*	1	1	0	0	1	0
(x1, -10) Divide By 10	1	1	0	1	0	1
(x2, -100) Divide By 50*	1	1	0	0	1	1
(x1, -100) Divide By 100	1	1	0	1	0	0

*These factors include both a resolution multiplier and a decade prescaler.
1 = V_{DD} = High Level
0 = V_{SS} = Low Level

QUADRATURE COUNTING MODES

For Quadrature Times 1 counting, input "A" serves as the count input while input "B" serves as the quadrature input. (Input "B" is a pulse train shifted 90° away from "A".) The counter will count in a positive going direction when "A" is a negative going signal and "B" is low. The counter will count in a negative going direction when "A" is a positive going signal and "B" is low. All transitions on "A" are ignored when "B" is high. These logic rules provide the basis for anti-jitter operation which will prevent false counts from occurring, due to back-lash, vibration, chatter, etc.

TABLE II illustrates the level settings of the mode select inputs for the various modes of quadrature counting. The Times 2 Quadrature Mode works the same as Times 1 when "B" is low. But when "B" is high, counts are no longer ignored at "A". Instead, the logic rules for "A" are complemented, allowing both edges of "A" to be counted. This gives an effective doubling of display count but more importantly, doubles the resolution of the input. The Times 4 Mode extends this even further. Both "A" and "B" serve as count or quadrature input. In one instance, "A" will be the count input and "B" will be the quadrature input. In another instance, "B" will be the count input and "A" will be the quadrature input. This will result in counts and resolution four (4) times greater than in the Times 1 Mode. For counting rates on these modes, refer to the specification sheet (X2, X4, -10, -100 give an equivalent divide-by 2.5, 5, 25, and 50).

TABLE II

MODE	MS6	MS5	MS4	MS3	MS2	MS1
Times 1	1	1	0	1	1	1
Times 2	1	1	1	0	0	0
Times 4	1	1	1	0	0	1
(x4, -10) Divide By 2.5*	1	1	1	1	0	1
(x2, -10) Divide By 5	1	1	1	0	1	0
(x1, -10) Divide By 10*	1	1	1	1	1	0
(x4, -100) Divide By 25	1	1	1	1	0	0
(x2, -100) Divide By 50*	1	1	1	0	1	1
(x1, -100) Divide By 100*	1	1	1	1	1	1

*These factors include both a resolution multiplier and a decade prescaler.
1 = V_{DD} = High Level
0 = V_{SS} = Low Level

ANTI-COINCIDENCE SUMMING MODES

For Anti-Coincidence Summing, input "A" and input "B" both serve as Add Inputs. These modes effectively separate count pulses which may simultaneously occur at the two inputs. The unit then processes the count pulses into a string of time-separated pulses so that the internal counter will not lose any counts. Both inputs respond to the negative going transition in the Times 1 Mode.

TABLE III illustrates the level settings of the Mode Select Inputs for the various modes of Anti-Coincidence Summing.

Note: The maximum count rate for all Anti-Coincidence counting modes is 20 KHz.

TABLE III

MODE	MS6	MS5	MS4	MS3	MS2	MS1
Times 1	0	1	0	0	0	0
(x1, -10) Divide By 10	0	1	0	1	0	1
(x1, -100) Divide By 100	0	1	0	1	0	0

1 = V_{DD} = High Level
0 = V_{SS} = Low Level

ANTI-COINCIDENCE ADD/SUBTRACT MODES

For Anti-Coincidence Add/Subtract counting, input "A" serves as the Add Input and "B" serves as the Subtract Input. This mode is identical to the Anti-Coincidence Summing Mode with the exception that all counts appearing at "B" will now subtract from the total counts. Both inputs respond to the negative going transition in the Times 1 Mode.

TABLE IV illustrates the level settings of the Mode Select Inputs for the various modes for Anti-Coincidence Add/Subtract counting.

Note: The maximum count rate for all Anti-Coincidence counting modes is 20 KHz.

TABLE IV

MODE	MS6	MS5	MS4	MS3	MS2	MS1
Times 1	0	0	0	0	0	0
(x1, -10) Divide By 10	0	0	0	1	0	1
(x1, -100) Divide By 100	0	0	0	1	0	0

1 = V_{DD} = High Level
0 = V_{SS} = Low Level

DECIMAL POINT AND LEADING ZERO BLANKING SELECTION

TABLE V illustrates the level settings required for decimal point selections, except for the last one shown, have leading zero blanking. As can be seen from the Table, the zero immediately to the left of the decimal point is turned on, while digits to the left of that zero are turned off.

The TEST MODE is implemented by: (1) setting DP1 through DP3 low; (2) pulling reset low; (3) applying one pulse to the count input; (4) pulling reset high; (5) applying

pulses to the count input. All digits will then increment simultaneously from zero.

TABLE V

MODE	D.P.3	D.P.2	D.P.1
Test Mode	0	0	0
0	0	0	1
0.0	0	1	0
0.00	0	1	1
0.000	1	0	0
0.0000	1	0	1
0.00000	1	1	0
000000	1	1	1

TYPICAL APPLICATIONS

BI-DIRECTIONAL UP/DOWN COUNTING

In this application, a continuous coating of adhesive is applied to a flexible material, which is then taken up on a large roll. Whenever a flaw is detected, the entire process is stopped. Since inertia exists in the system, a certain amount of over-run will occur. This, in turn, will require reversing the system in order to bring the flaw back to the adhesive applicator. The SUPER SUB-CUB can be used to correct the over-run problem by causing the count to decrease when the process is reversed.

The SUPER SUB-CUB is set up for Bi-Directional UP/DOWN counting. The Latch pin is used to "freeze" the display when a defect occurs. Input "A" serves as the count input which is connected to an open collector output LSC Length Sensor. This sensor generates 100 pulses/foot of material travel. (With 100 pulses/foot going into the counter, the decimal point is selected so that the display will indicate feet and hundredths of feet.) Input "B" serves as the UP/DOWN direction control pin. This pin is connected to a contact which opens when the system reverses direction, causing the counter to count "down". Since the unit is measuring in hundredths of a foot and very large rolls are used, it is possible that the count could exceed the display capability of six (6) digits. To avoid this problem, a button is connected which, when pressed, causes the unit to display the six (6) most significant digits of the internal 8-digit counter. In addition, the decimal point is removed when the button is held down.

The operation of the system is described as follows. Whenever a flaw is detected, the Latch pin will be pulled high, "freezing" the display at the reading where the flaw occurred. At the same time, the machine is stopped and the applicator is turned off. Due to inertia within the system, internal counts increase until the system comes to a complete stop. The operator then notes the reading on the counter display, releases the latch pin (the display then reveals the total length), and reverses the machine until the displayed value matches the noted value. When this match occurs, the flawed area is beneath the applicator area where it can be corrected.

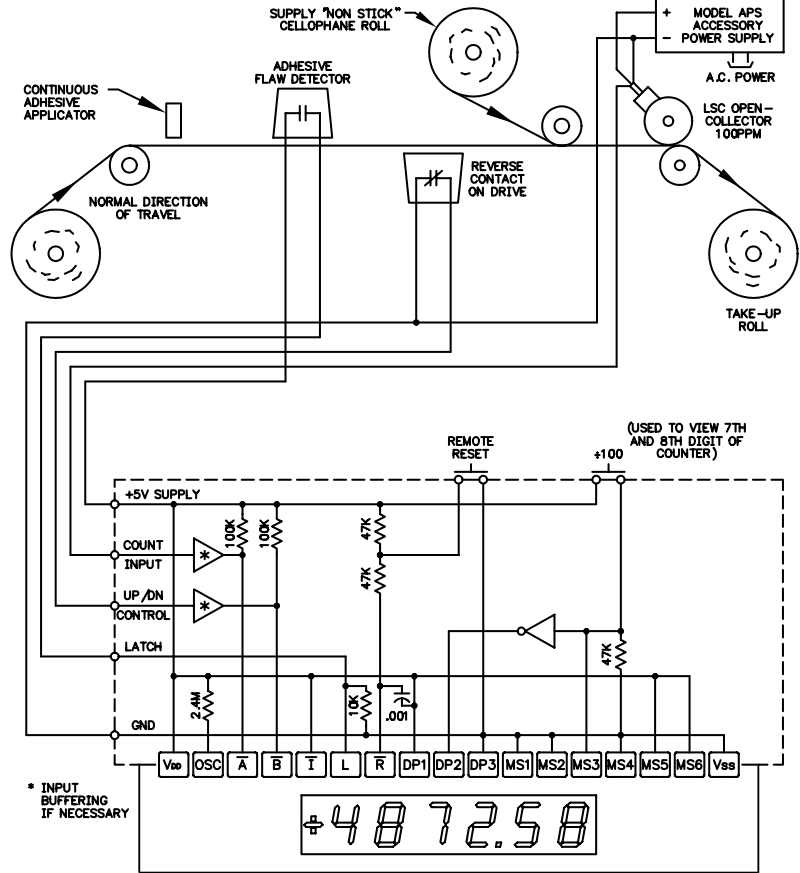

QUADRATURE TIMES FOUR

In this application, it is necessary to keep track of the exact position of a work table. The work table can be moved left or right and is driven by a lead screw. Because the two requirements of critical positioning and direction reversal must be satisfied, the Quadrature Mode of the SUPER SUB-CUB is selected. An RPGB with 10 PPR, quadrature, current sinking output is coupled to the screw shaft. The screw shaft moves the table one inch for every 25 revolutions which yields 250 pulses/inch of travel. But in this application, a higher degree of resolution is needed without using a higher resolution sensor. Therefore, the Times Four Quadrature Mode is selected which results in 1000 pulses per inch of travel or 0.001" increments of resolution.

The drawing illustrates connections for the inputs and mode select lines, including buffering of the two inputs. (The diodes are used to block the 12 VDC signal of the RPG from the SUPER SUB-CUB inputs.) The decimal point is placed in the third position so the reading is in inches and one-thousandths of inches.

With the set-up shown, the operator can place the table at any reference point desired, reset the SUPER SUB-CUB and make all measurements with regard to this reference. Movement to the left of this reference will provide a negative reading, while movement to the right of this reference will provide a positive numerical reading. Switching the count and quadrature inputs will cause movement left to be positive (+) while movement to the right will be negative (-). As shown in the drawing, the work table is 53.475" to the left of the reference point.

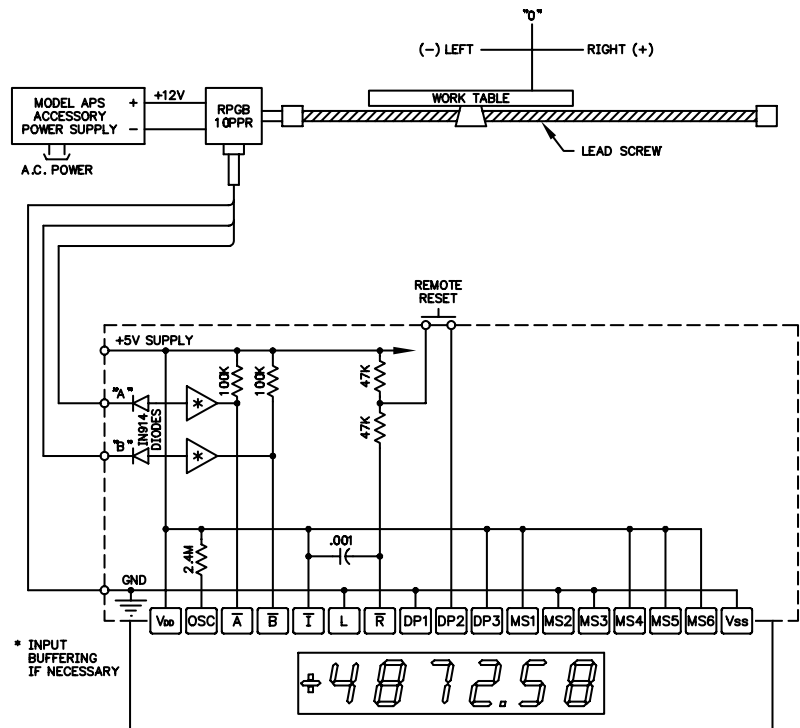

TYPICAL APPLICATIONS (CONT'd)

ANTI-COINCIDENCE ADD/SUBTRACT

In this application, it is necessary to keep track of the number of people in an enclosed area, both for security and safety reasons. Typically, such places could be a nightclub, amusement centers, government buildings, stores and other areas where population count is important.

This function is accomplished by first counting the number of people going into the area and next, subtracting the number of people leaving the area. Since people could be entering and leaving the area simultaneously, the counts would be lost if there were not some means of accounting for the coincident counts. The Anti-Coincidence Add/Subtract Mode of the SUPER SUB-CUB satisfies this requirement.

The set-up for this application/system is illustrated as shown. A turnstile, which has contact closure outputs, is used to activate the inputs. The "ENTER" turnstile is connected to the Add Input ("A") of the SUPER SUB-CUB while the "EXIT" turnstile is connected to the Subtract Input ("B"). When people enter the area through the "ENTER" turnstile, the counter is incremented. When people leave the area through the "EXIT" turnstile, the counter is decremented. Because the Anti-Coincidence Mode is used, counts occurring at either input at any time will not be lost.

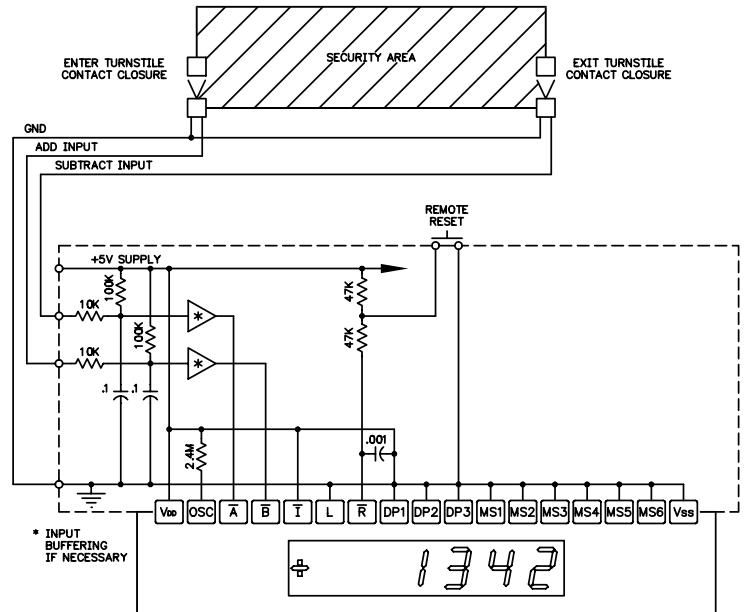

PANEL BEZEL KIT FOR THE SUPER SUB-CUB P/N HWK50000

This kit provides a convenient way to adapt the SUPER SUB-CUB for panel mounting. The kit includes the black plastic bezel, the panel and internal window gaskets, P.C. Board, 12" ribbon cable and mounting screws.

ASSEMBLY

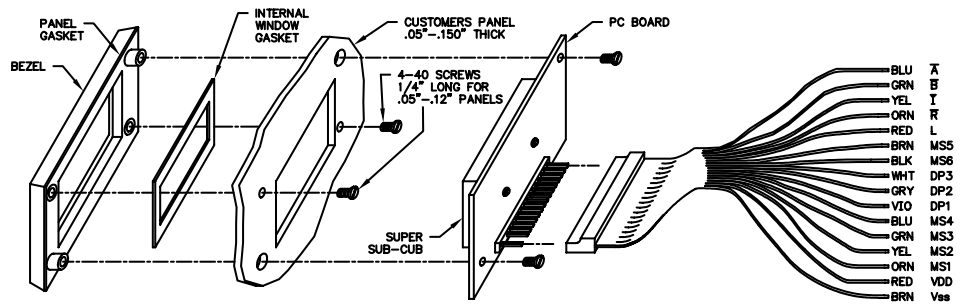

DIMENSIONS & PANEL CUT-OUT In inches (mm)

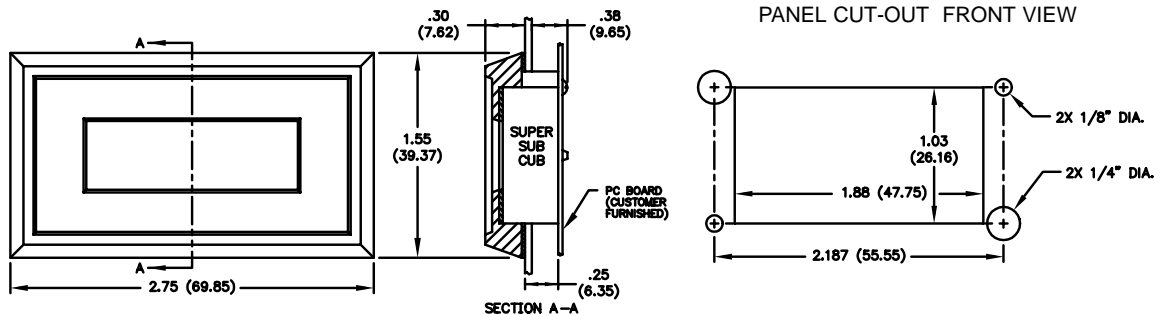

SUPER SUB-CUB PROTOTYPING BOARD

This board is a handy way of doing experimental and prototyping work with the SUPER SUB-CUB. It easily plugs into standard 0.1" spacing bread boards. This in turn, greatly simplifies bread board work.



SUPER SUB-CUB
PROTO TYPING
BOARD
P/N DMOSCB03

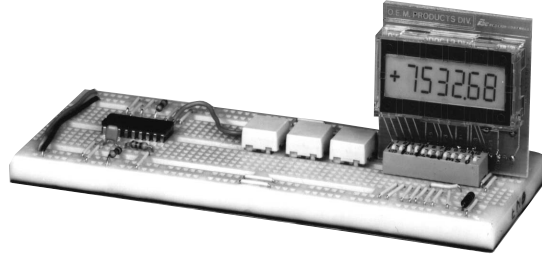

ORDERING INFORMATION

MODEL NO.	DESCRIPTION	PART NUMBER
SSCUB2	SUPER SUB-CUB Display/Counter Module	SSCUB200
HWK 5	*SUPER SUB-CUB Panel Bezel Kit w/P.C. Board & Cable	HWK50000
HWK 3	*SUPER SUB-CUB Panel Bezel Kit w/o P.C. Board & Cable	HWK30000
--	*SUPER SUB-CUB Prototype P.C. Board	DMOSCB03
* Does not include SUPER SUB-CUB Display/Counter Module. Order SUPER SUB-CUB Separately.		

LIMITED WARRANTY

The Company warrants the products it manufactures against defects in materials and workmanship for a period limited to one year from the date of shipment, provided the products have been stored, handled, installed, and used under proper conditions. The Company's liability under this limited warranty shall extend only to the repair or replacement of a defective product, at The Company's option. The Company disclaims all liability for any affirmation, promise or representation with respect to the products.

The customer agrees to hold Red Lion Controls harmless from, defend, and indemnify RLC against damages, claims, and expenses arising out of subsequent sales of RLC products or products containing components manufactured by RLC and based upon personal injuries, deaths, property damage, lost profits, and other matters which Buyer, its employees, or sub-contractors are or may be to any extent liable, including without limitation penalties imposed by the Consumer Product Safety Act (P.L. 92-573) and liability imposed upon any person pursuant to the Magnuson-Moss Warranty Act (P.L. 93-637), as now in effect or as amended hereafter.

No warranties expressed or implied are created with respect to The Company's products except those expressly contained herein. The Customer acknowledges the disclaimers and limitations contained herein and relies on no other warranties or affirmations.

Red Lion Controls
20 Willow Springs Circle
York PA 17402
Tel +1 (717) 767-6511
Fax +1 (717) 764-0839

Red Lion Controls France
56 Boulevard du Courcerin, Batiment 21,
ZI Pariest F-77183 Croissy Beaubourg
Tel +33 (64) 80 12 12
Fax +33 (64) 80 12 13

Red Lion Controls BV
Basicweg 11b
NL - 3821 BR Amersfoort
Tel +31 (33) 472 32 25
Fax +31 (33) 489 37 93